

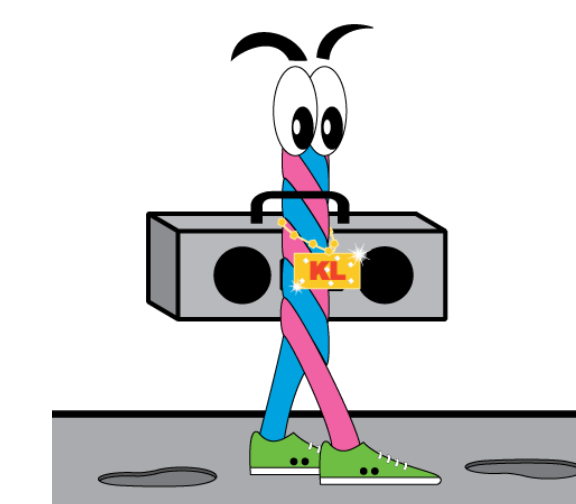

The University of New Mexico

Lawrence J. Herskowitz\*, Anthony L. Salvagno, Andy Maloney,  
Brian P. Josey, and Steven J. Koch

University of New Mexico, Center for High Technology Materials and Department of Physics and Astronomy, Albuquerque, NM  
\*Lherskow@unm.edu

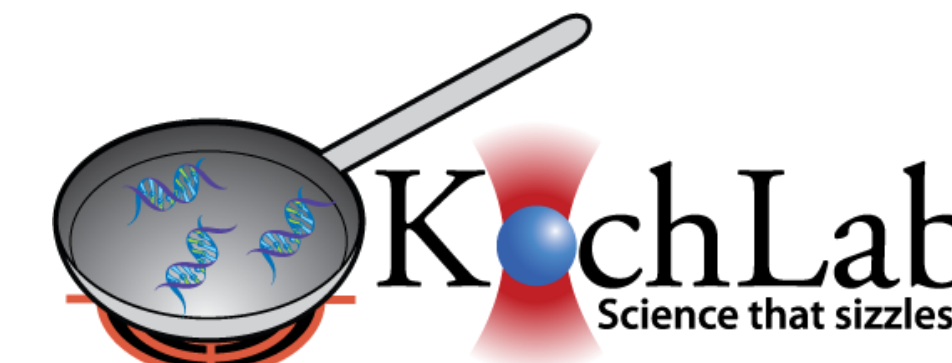

## Kinesin-1 Kinetics and Stochastic Simulation Overview

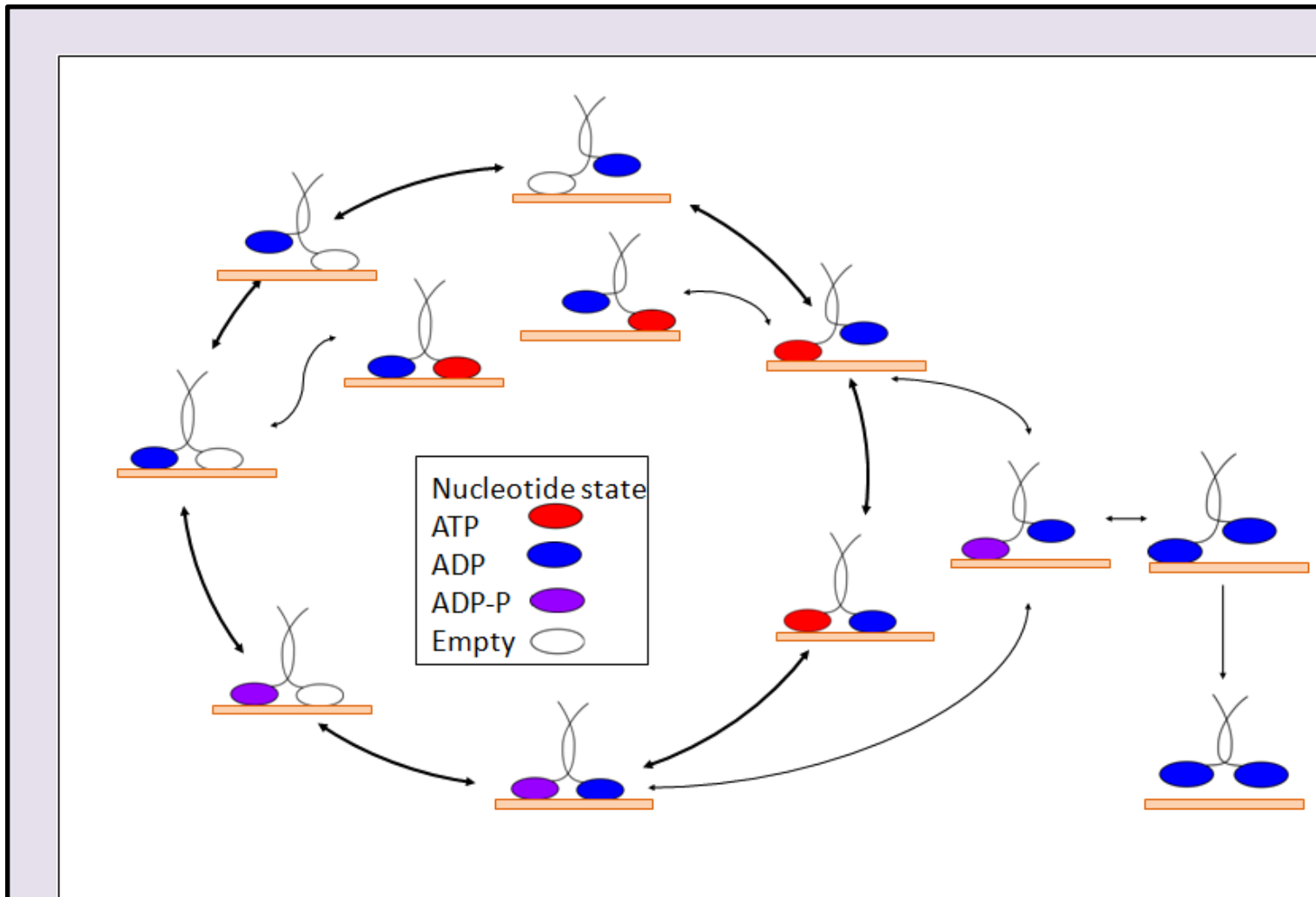

This diagram shows the currently believed core stepping cycle in thicker arrows as well as two theoretically possible branches. These aren't the only possible branches just two of them selected to exemplify how complicated the stepping process may be. A stepping mechanism with many branches may be more realistic than simulating kinesin's movement with only the core cycle. For the kinesin motor to detach from the microtubule it must enter a state that is not found on the core cycle. Not all branches lead to detachment as seen above some can just give an alternate route to another state on the core cycle. Also allowing the kinesin to enter a previous state shown here with the double headed arrows may be an important concept that can affect kinesin properties such as stall force and ATP consumption.

This is a simplified diagram of the software used in this simulation. This was programmed in Labview 7.1. The sub.vi's (which are functions in Labview programming) labeled "k's next states" finds the rate constants for the head to transition to another state. This .vi allows for the heads to interact through their rate constants. The sub.vi labeled "Choose New State" is the Monte Carlo portion of the program that finds random times for each transition and then chooses the transition that occurs in the shortest time<sup>1</sup>.

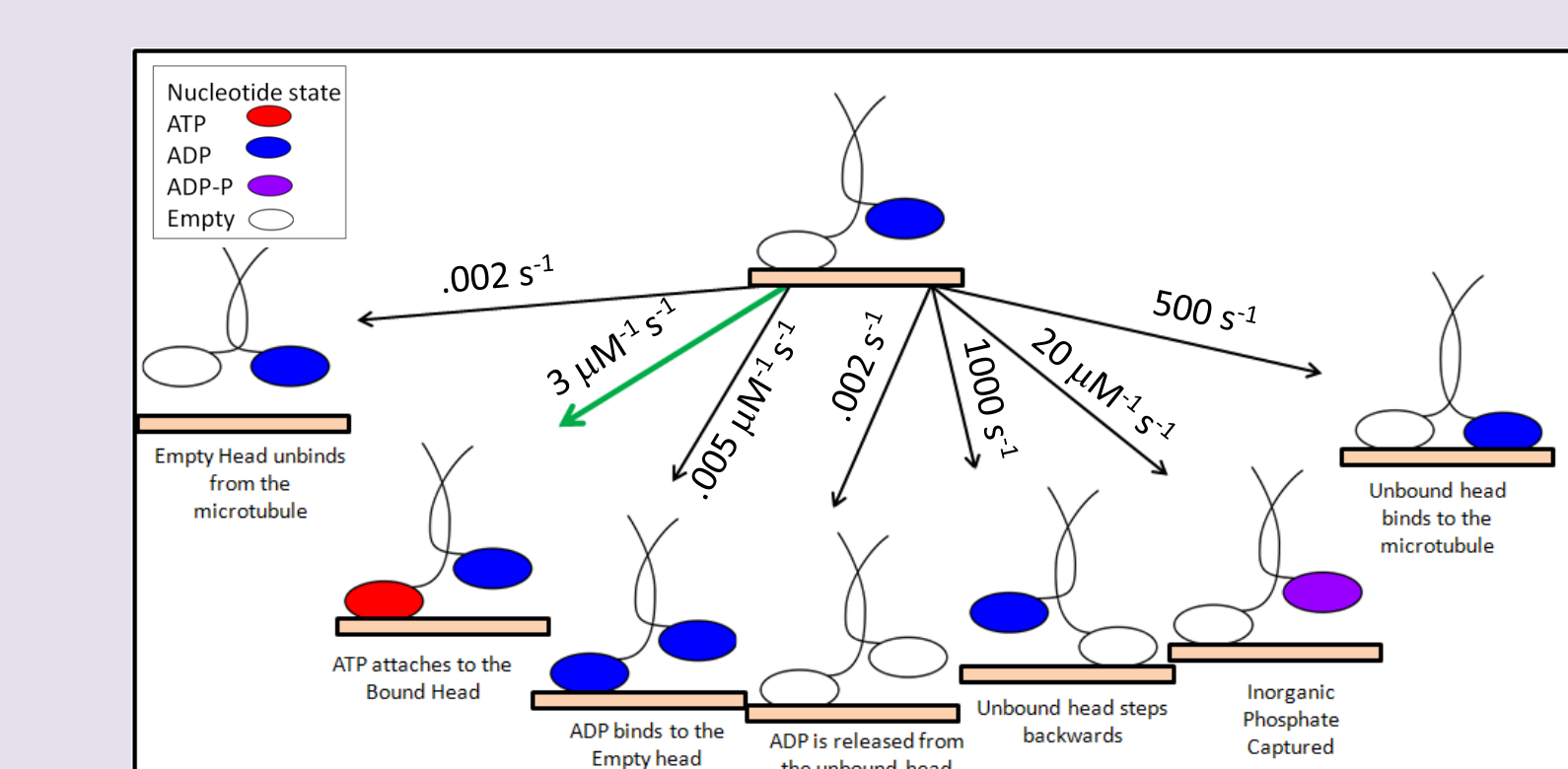
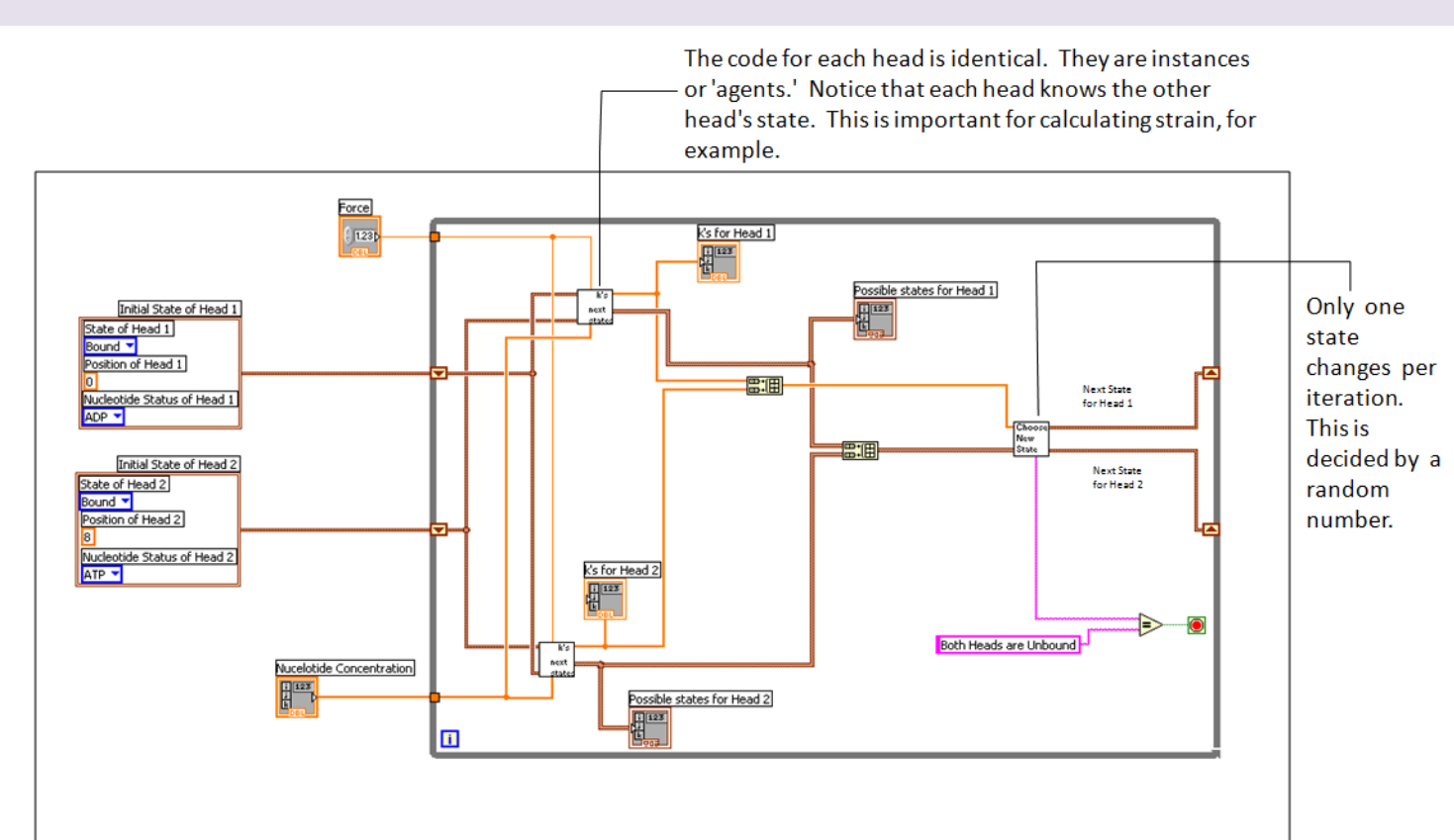

The state shown at the top—empty head bound to the microtubule behind an unbound ADP head—can transition to seven different states. The current state, an empty head bound to the microtubule behind a head unbound to the microtubule with ADP attached to the head has seven possible states it can become. The green line shows the most probable transition which is ATP binding to the empty head. The simulation allows for all of these transitions though the probability can be low for some of them. In our agent-based simulation, we use a diffusive search as opposed to a lever arm model. The diffusion of the head from front/back has a rate constant of  $1000 \text{ s}^{-1}$ .

## Experiments and Results

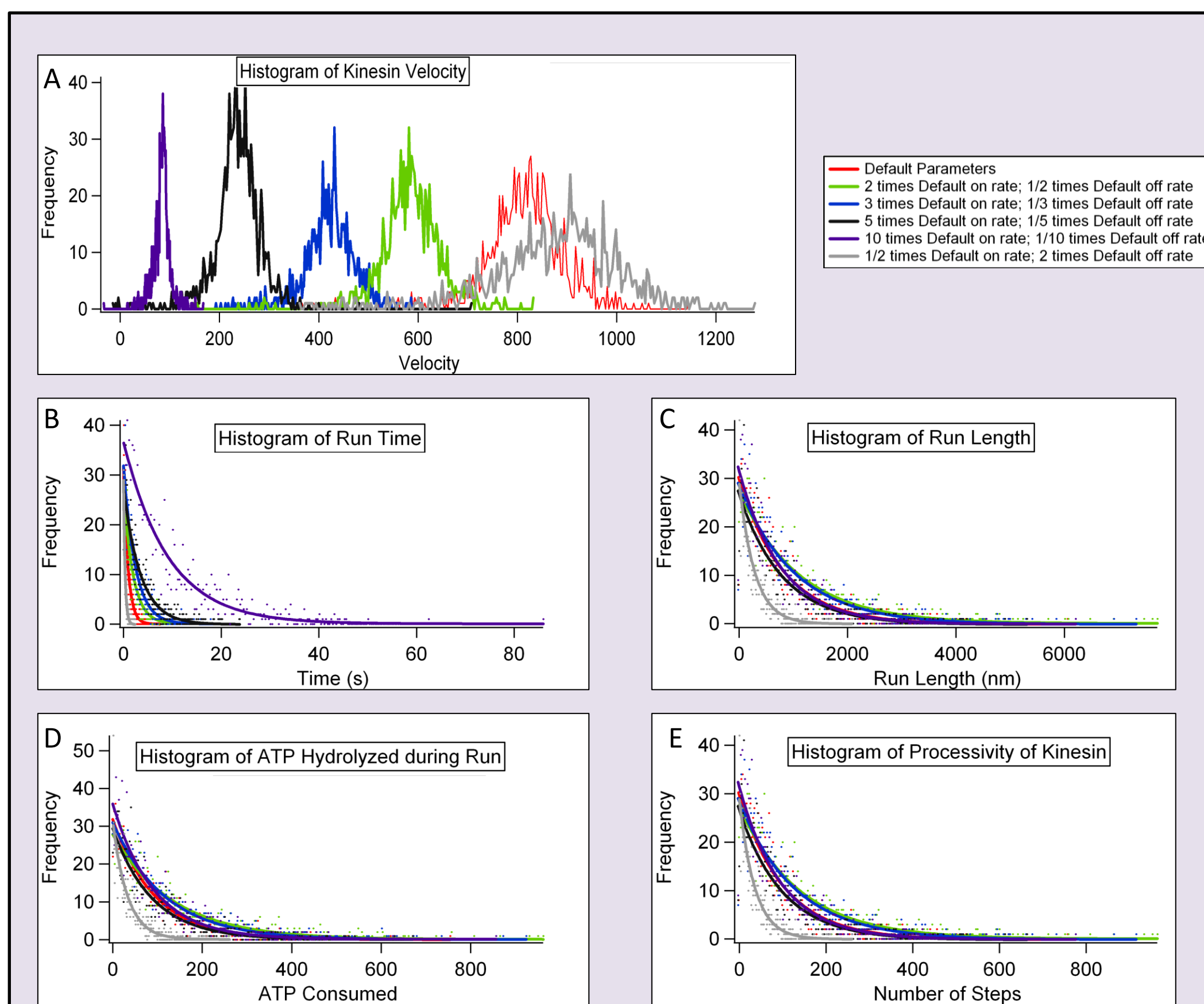

These histograms show the consequences of varying on and off rates of kinesin heads binding and unbinding from the microtubule. We ran these experiments to get a qualitative idea of how osmotic stress or chemical denaturants may modify kinesin behavior. The red plots in this figure represents kinesin under normal conditions. The gray plot may indicate what might happen with the use of chemical denaturants. (A) Velocity of the kinesin decreases as the head unbinding rate decreases. This velocity is decreasing because the kinesin is staying on the microtubule for a longer time. This is seen in (B) as the head unbinding rate decreases the time also increases. (C) With the exception of the grey plot, head unbinding rate does not affect the distance the kinesin travels. (D) The ATP hydrolyzed by the kinesin is not affected by the head unbinding rate. (E) The processivity of the kinesin is also unaffected by the head unbinding rate. The kinesin also maintains a 1:1 ratio of ATP hydrolyzed to kinesin steps.

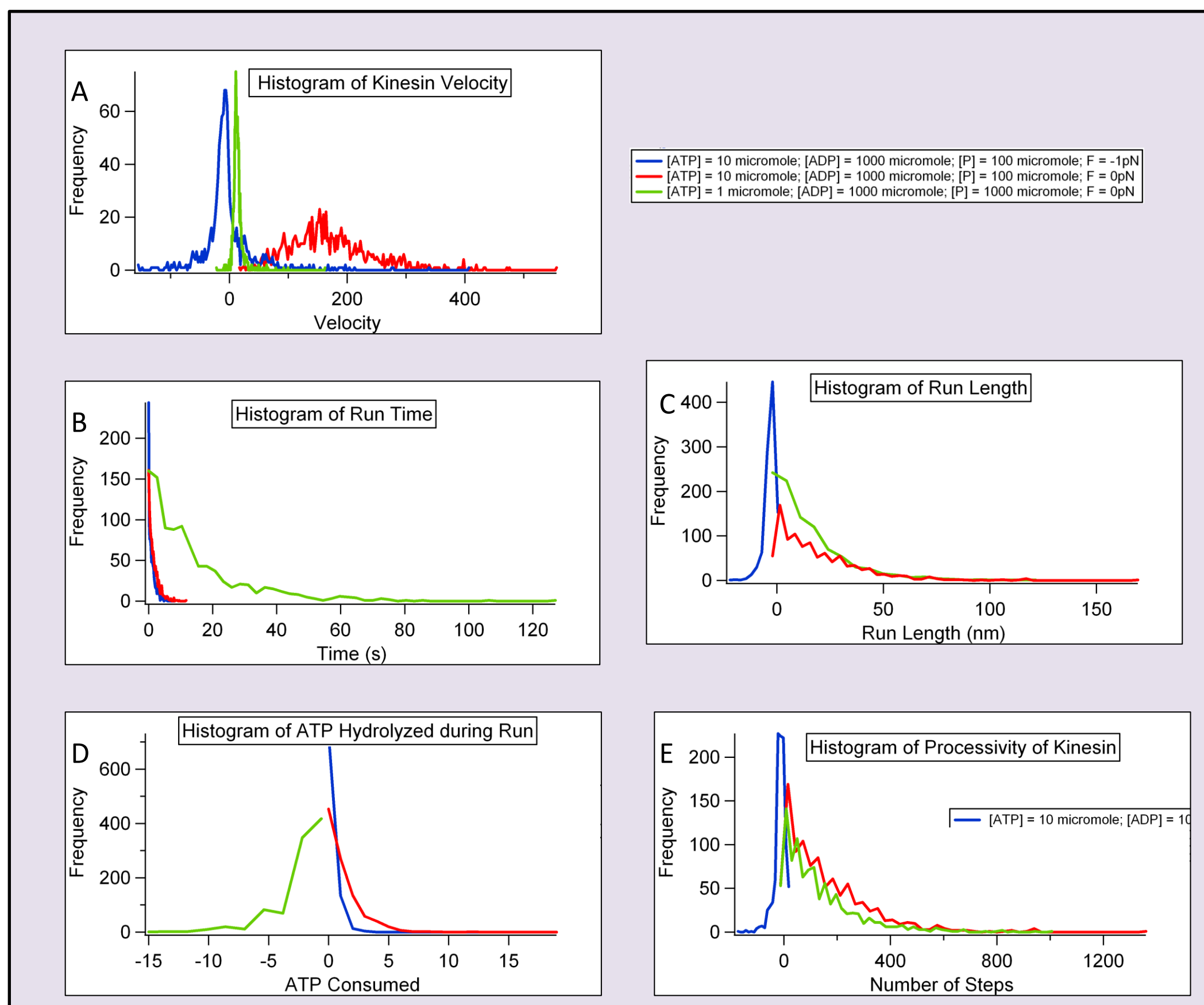

This figure is comprised of graphs that show the effect of decreasing the ATP and increasing the ADP and P concentrations. The blue plots have the same concentration level as the red plots however there is a small force applied pulling the kinesin stalk away from its directed motion. (A) This graph shows that the velocity is much slower than the default parameter shown above. With a small force pulling backward in this set up, the kinesin does walk backward however not with a high velocity. (B) The time it takes the kinesin to fall off the microtubule is not effected by the force. However, decreasing the ATP concentration and increasing the product concentration enough will increase the time the kinesin is attached to the microtubule. This accounts for the lower velocity results compared to the other plots. (C) With a small force, the kinesin will walk backwards. This is shown as a negative run length. (D) With a low ATP and a high product concentration it might be possible for kinesin to synthesize ATP while walking forward. This is shown with negative ATP consumption values. (E) This graph shows again that the kinesin with a back pulling force on it can step backwards; though with far less processivity.

For a list of the references used to create the rate constants and for the rate constants used in the simulation see [http://openwetware.org/wiki/User:TheLarry/Rate\\_Constants](http://openwetware.org/wiki/User:TheLarry/Rate_Constants)

- Selected References**
- Gillespie, D. (1976). A general method for numerically simulating the stochastic time evolution of coupled chemical reactions. *Journal of computational physics*, 22(4), 403–434. Elsevier. Retrieved from <http://linkinghub.elsevier.com/retrieve/pii/002199176900413>.
  - Cheezum, M. K., Walker, W. F., & Guilford, W. H. (2001). Quantitative comparison of algorithms for tracking single fluorescent particles. *Biophysical journal*, 81(4), 2378–88. doi: 10.1016/S0006-3495(01)75884-5.
  - Herskowitz, Lawrence and Koch, Steven. An open source LABVIEW platform for simulating image series of fluorescent microtubules in gliding assays. Available from Nature Precedings <http://dx.doi.org/10.1038/npre.2010.4374.1> (2010).
  - Guydosh, N., & Block, S. (2006). Backsteps induced by nucleotide analogs suggest the front head of kinesin is gated by strain. In *Proceedings of the National Academy of Sciences* (Vol. 103). National Acad Sciences. Retrieved from <http://www.pnas.org/content/103/21/8054.full>.
  - Tomshige, M., Sturman, N., & Vale, R. (2006). Single-molecule observations of neck linker conformational changes in the kinesin motor protein. *NATURE STRUCTURAL AND MOLECULAR BIOLOGY*, 13(10), 887. Nature Publishing Group. Retrieved from <http://scholar.google.com/scholar?hl=en&btnG=Search&q=intitle:Single+molecule+observations+of+the+neck+linker+conformational+changes+in+the+kinesin+motor+protein#>

## Automated Microtubule Gliding Speed Analysis Software

Gliding assays performed by Andy Maloney. He is presenting his poster, *Speed Effects on Gliding Motility Assays Due to Surface Passivation and Osmotic Stress*, during this section.

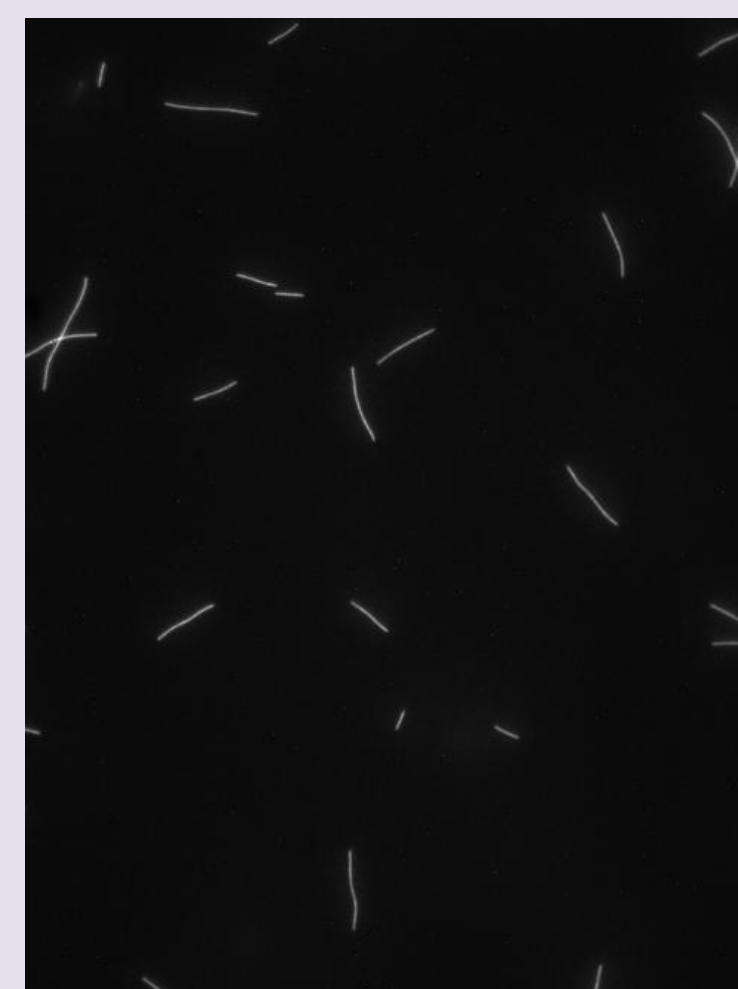

This is an image taken from a gliding motility assay.



The original image is segmented through thresholding and filter options such as "remove small objects" using functions from NI Vision 7.1.

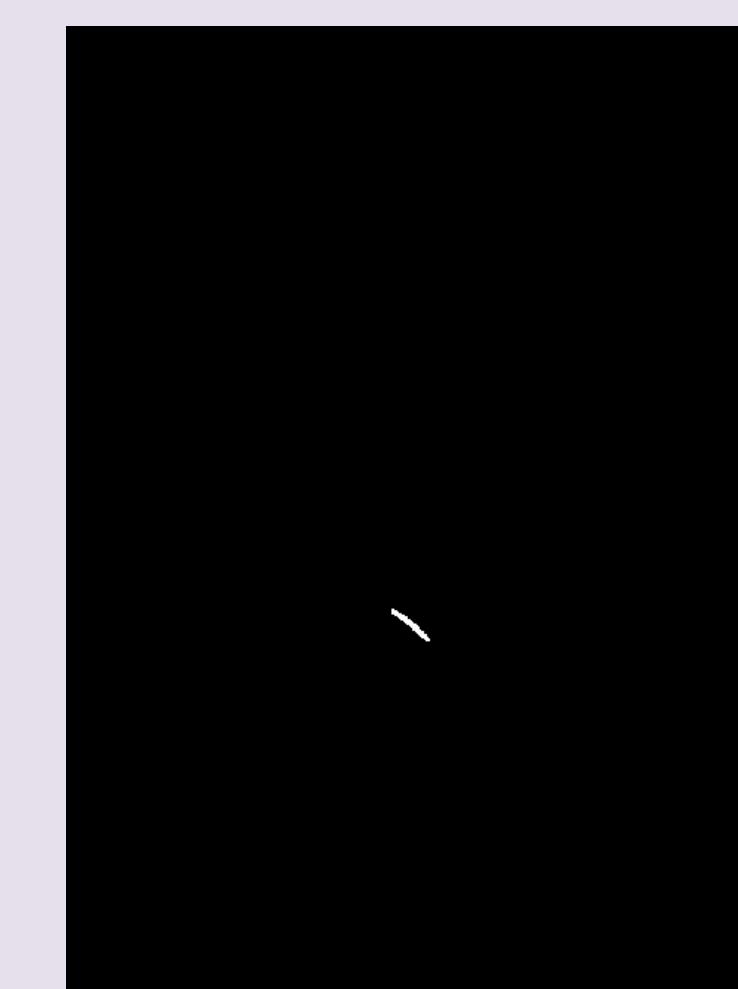

A mask of the desired microtubule is created using IMAQ Magic Wand.

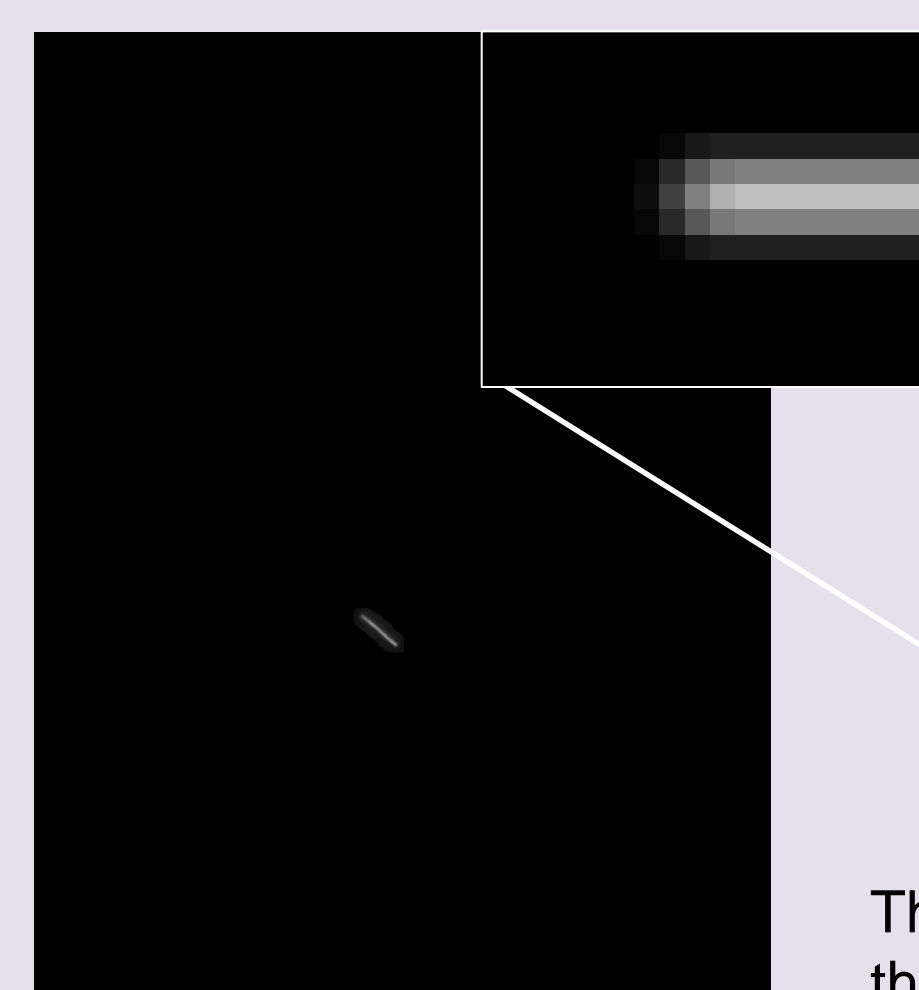

A template is matched to both ends of the microtubule using IMAQ Match Pattern 2

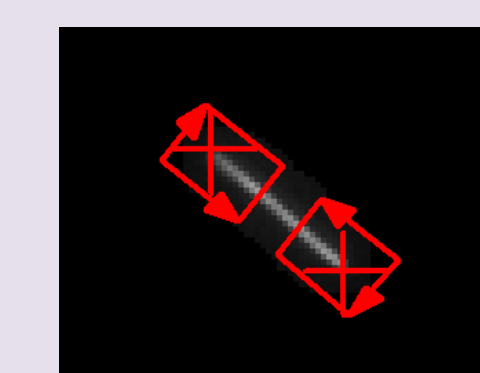

The ends points and projection angle of the microtubule are then extracted from the pattern matching algorithm.

The template is created through the convolution of a line with an airy disk<sup>2</sup>.

Using the mask the microtubule is cut out of the original image.



Various microtubules are tracked using automated tracking software.

## Extracting Gliding Speed from XY Tracking Data

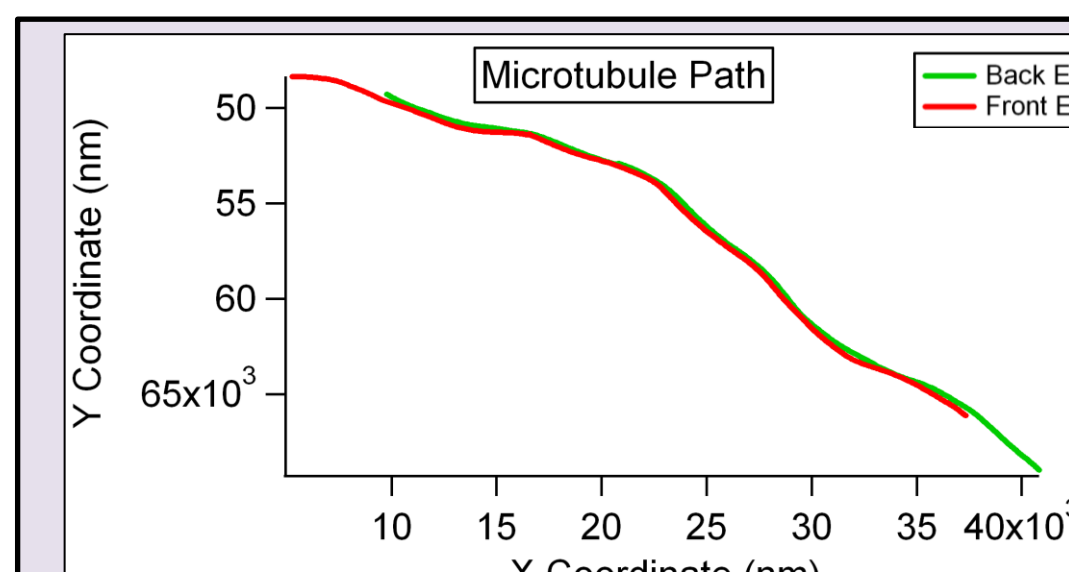

Using the end's coordinates, a path of the microtubule is created.

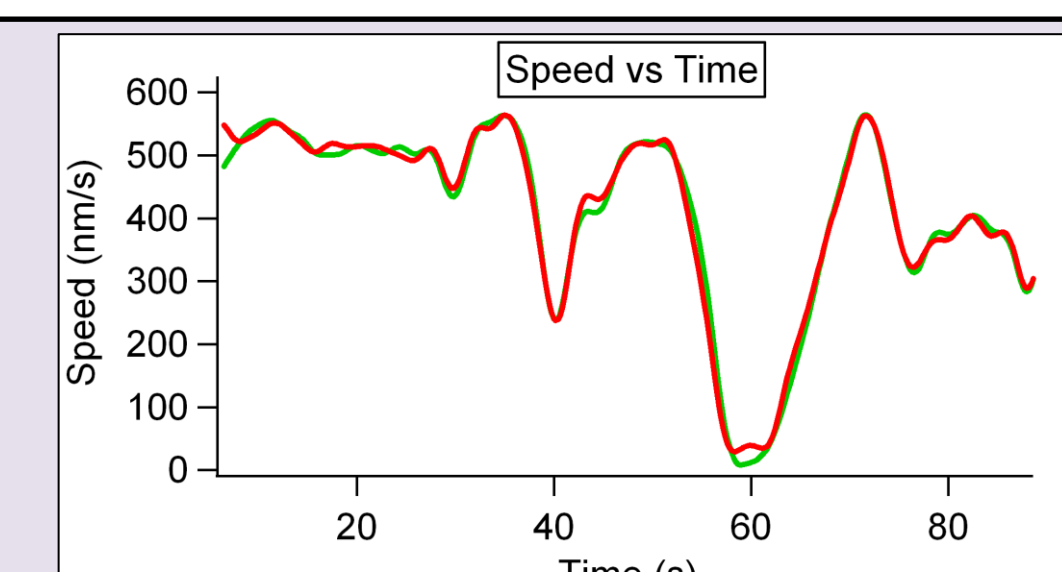

The speed data is created next using time data.

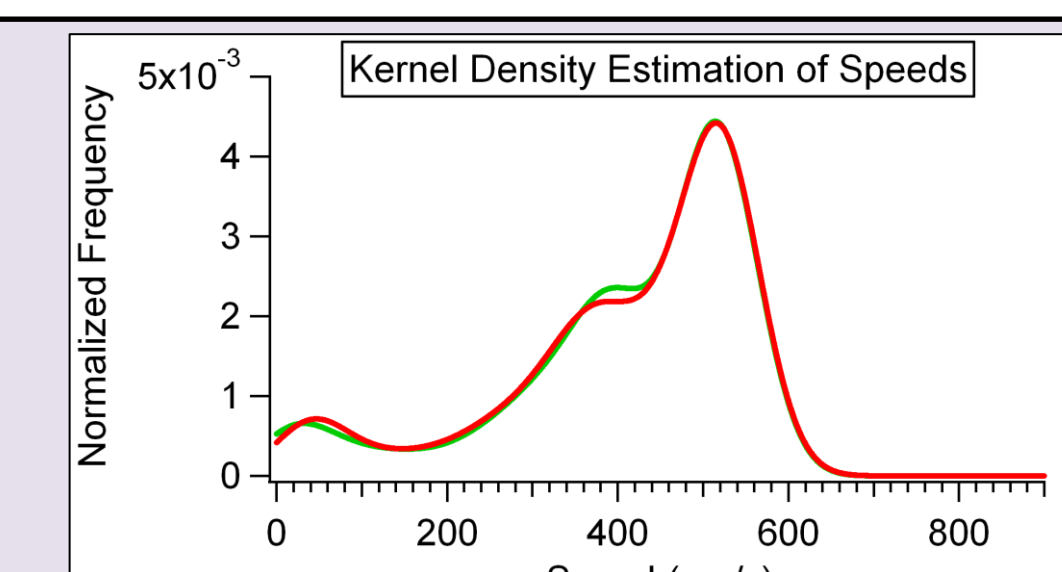

The probability density function of the speed is approximated using a Kernel Density Estimation (KDE) with a Gaussian Kernel of width 40 nm/s.

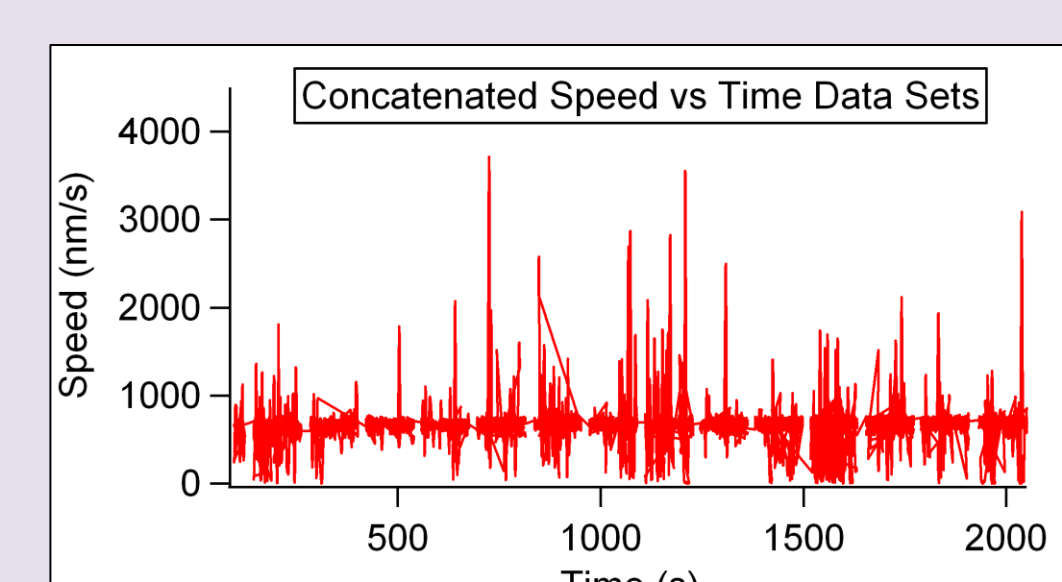

Analyzing the tracking data is an automated process. The velocity data is concatenated from all the microtubules tracked.

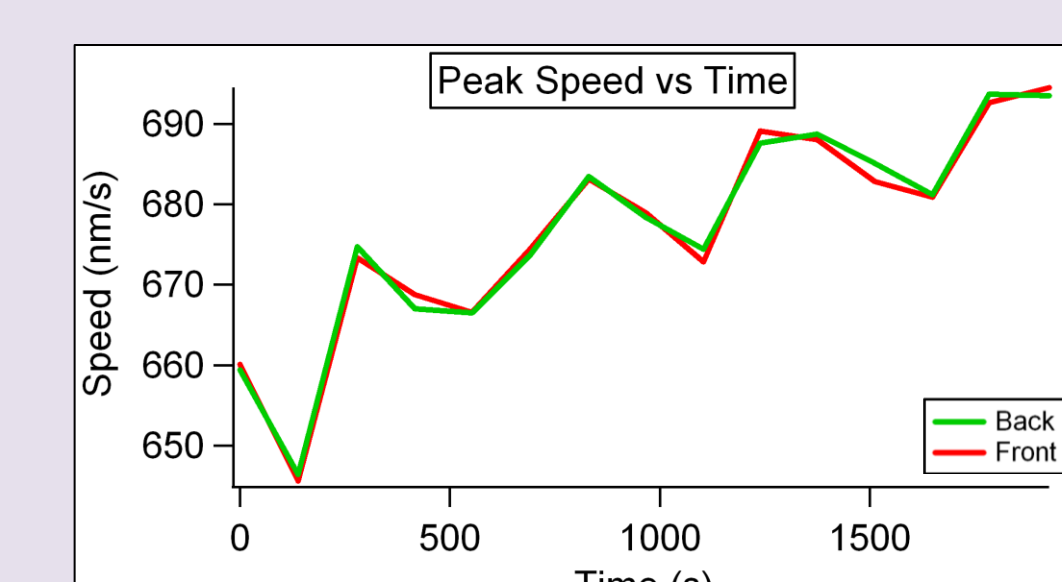

The peak of the PDF is used to measure the velocity of sets of microtubules. These peaks are used to chart the speed change over time.

See Andy Maloney's poster, *Speed Effects on Gliding Motility Assays Due to Surface Passivation and Osmotic Stress*, for more discussion of the speed increase with time.

## Testing Tracking Software with Simulated Images

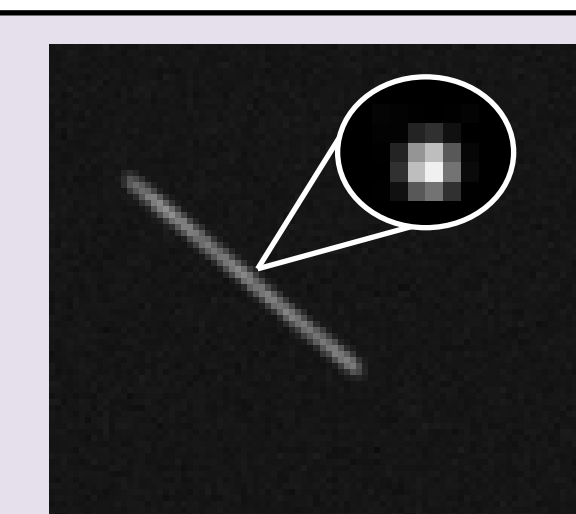

To best test the tracking software, images were created mimicking gliding motility assay images

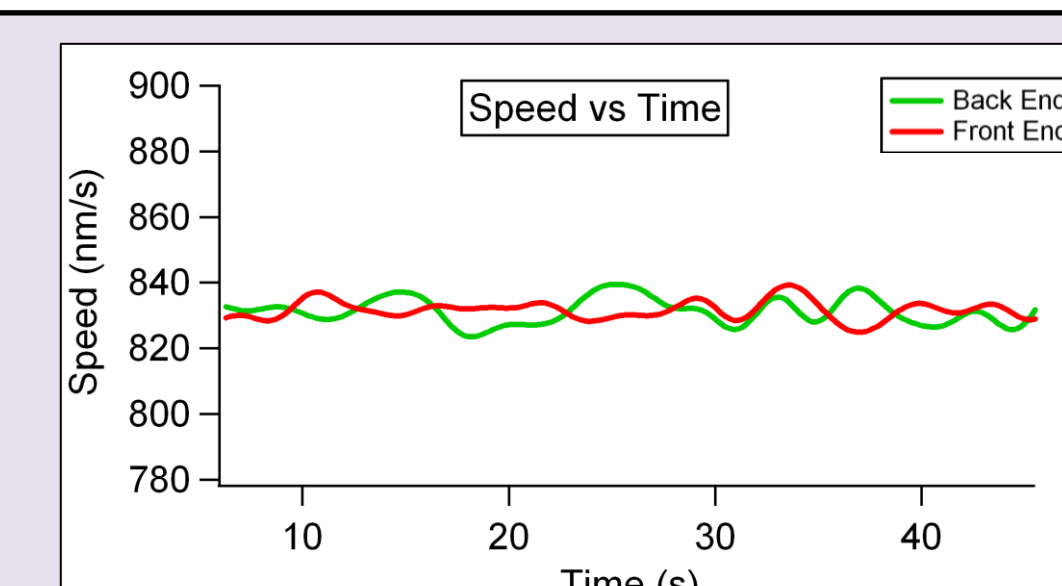

The speed data is generated from tracking a simulated microtubule with a uniform speed of 833.5 nm/s. The spread in the data is from noise in the tracking algorithm.

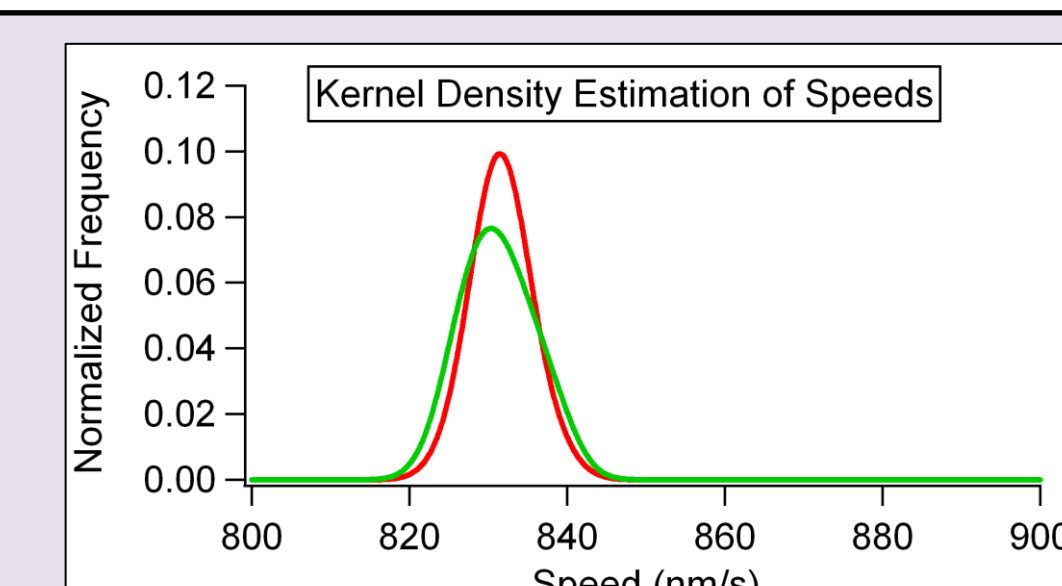

The peak velocity shown here is 831.5 and 830.4 nm/s for the front and back ends of the microtubule respectively.

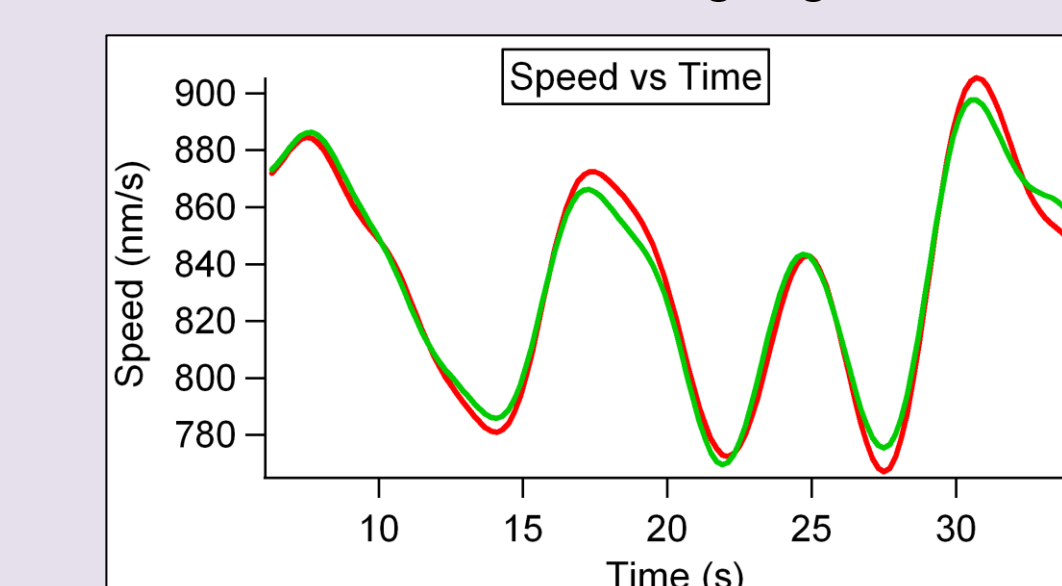

This speed data is generated from tracking a simulated microtubule with a changing step size, but with a mean speed of 833.5 nm/s.

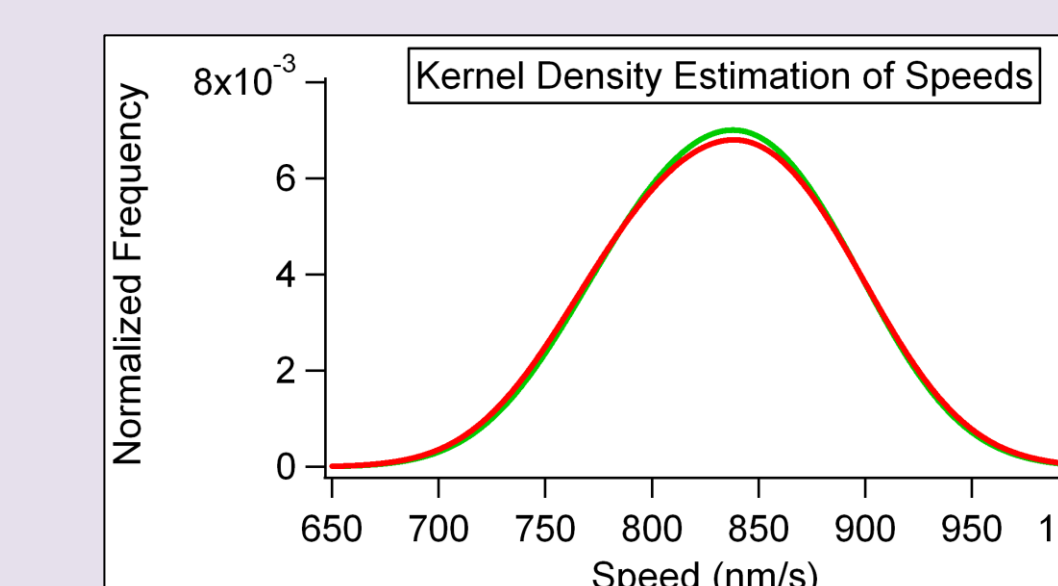

The peak values reported here are 838.2 and 838.0 nm/s for the front and back ends of the microtubule respectively.

All of this software is open source, and we are willing to help other scientists install and run the programs shown here.

**Acknowledgements**  
Haigui Liu for providing kinesin for experiments  
DTRA CB Basic Research Program under Grant No. HDTRA1-09-1-008  
Open Wetware for supplying the wiki where I keep my notebook  
National Instruments Labview

